

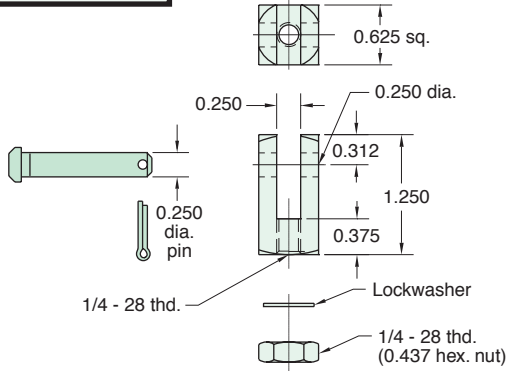

7/8" BORE MOUNTING BRACKETS

15015

Rod Clevis Assembly



15018-1

Foot Mounting Bracket

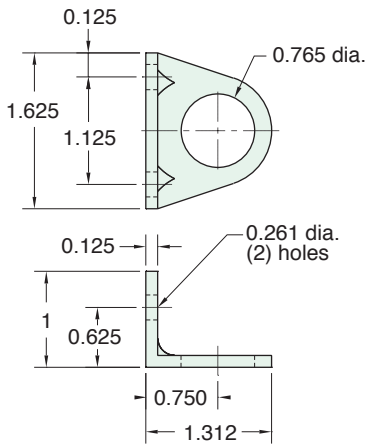

CUSTOMer solutions

If you need a product that fits your application perfectly, Clippard has the capability to design or modify one of its products to suit your exact needs. We understand that a standard catalog product may be close but not be exactly what you need. Let us know YOUR Need, and we will help to find YOUR Solution!

Special Cylinders

Clippard produced the first rolled-construction cylinder in 1949. Since then, we have produced thousands of special configurations from cartridge designs to low break-away miniature cylinders.

